

## Motore in continua con L293D

(2')

Il driver L293 ha 4 amplificatori di potenza e può pilotare 4 motori in continua o i 4 avvolgimenti ABCD di un motore passo-passo unipolare

o 2 motori in continua bidirezionali...

o 1 passo-passo bipolare

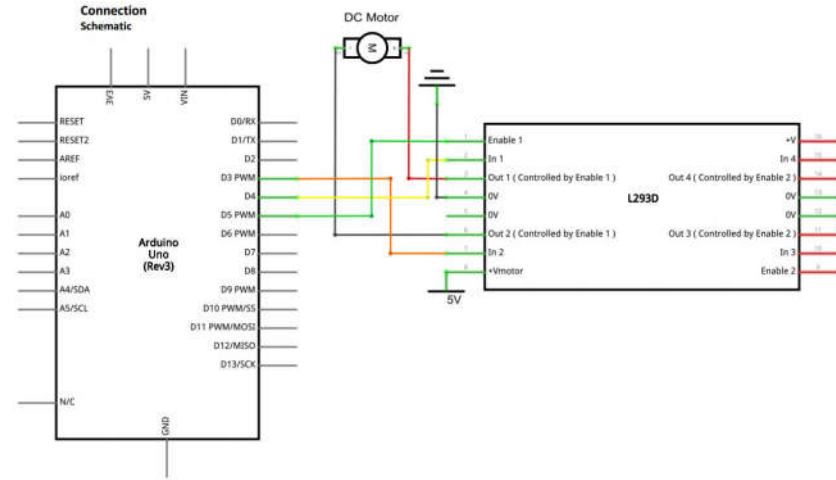
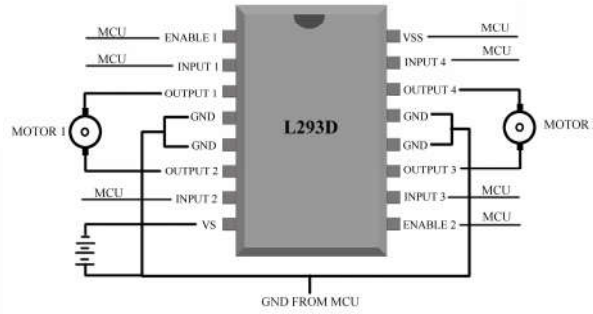
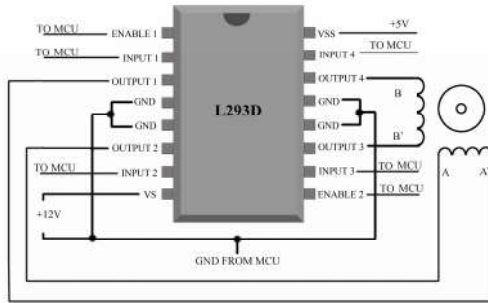

I diodi che qui sono disegnati fuori, in realtà sono dentro all'integrato

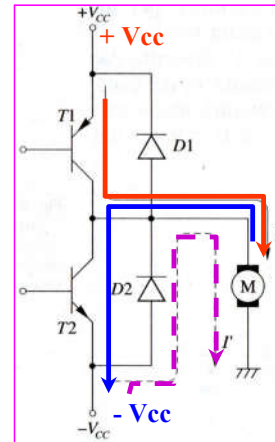
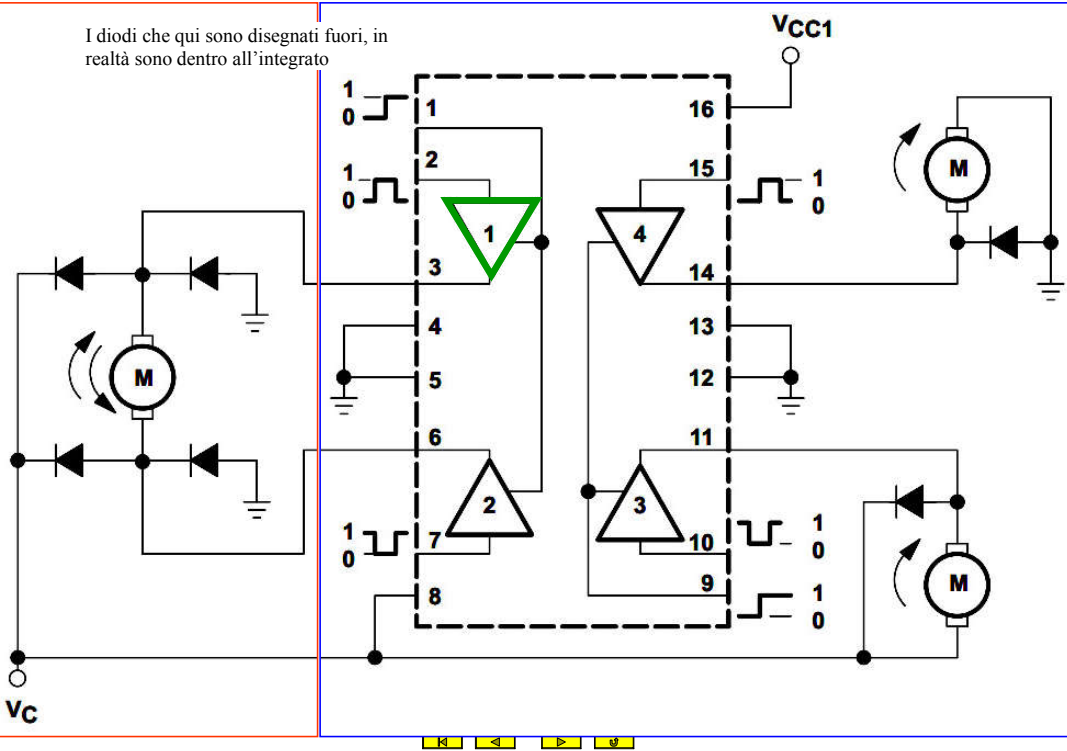

Col pilotaggio a semiponte si risparmiano 2 BJT ma serve un'alimentazione duale

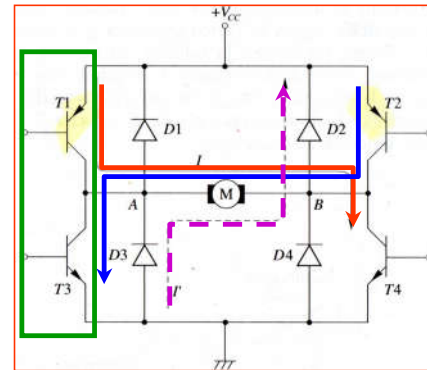

...con pilotaggio a ponte intero (o ponte H)

